

**KSTAR**



## **KAC50DP Industrial and Commercial Power Conversion System**

**User Manual**

Shenzhen Kstar New Energy Co., Ltd.

V1.0



# Contents

|      |   |    |
|------|---|----|
| 1    | About This Manual .....                       | 1  |
| 1.1  | Introduction .....                            | 1  |
| 1.2  | Applicable Products .....                     | 1  |
| 1.3  | Naming Rules of Product Models.....           | 1  |
| 1.4  | Manual Description .....                      | 1  |
| 1.5  | Description of Signs.....                     | 2  |
| 2    | Safety Instructions .....                     | 2  |
| 2.1  | Personnel Requirements.....                   | 3  |
| 2.2  | Safety Warning Operation .....                | 3  |
| 2.3  | Protection of Symbols on Equipment Body ..... | 3  |
| 2.4  | Matters on Electricity Safety.....            | 3  |
| 2.5  | Requirements of Environmental Space.....      | 4  |
| 2.6  | Specification of Live Test.....               | 4  |
| 2.7  | Parameters Setting.....                       | 5  |
| 2.8  | Maintenance or Overhaul Specifications .....  | 5  |
| 2.9  | Product Scrapping .....                       | 5  |
| 2.10 | Other Precautions .....                       | 6  |
| 3    | Product Introductions.....                    | 7  |
| 3.1  | Power Conversion System .....                 | 7  |
| 3.2  | Product Appearance.....                       | 8  |
| 3.3  | Main Power Topology .....                     | 9  |
| 3.4  | Product Features.....                         | 9  |
| 3.5  | Communication Scheme .....                    | 9  |
| 4    | PCS Modes and Functions .....                 | 11 |
| 4.1  | Mode Introduction.....                        | 11 |
| 4.2  | PCS Functions .....                           | 12 |
| 4.3  | Introduction to PCS States .....              | 13 |
| 5    | Guide for Mechanical Installation .....       | 14 |
| 5.1  | Precautions before Installation.....          | 14 |
| 5.2  | Installation Process .....                    | 14 |
| 5.3  | Preparation for Installation .....            | 15 |
| 5.4  | Machine Transportation .....                  | 16 |
| 5.5  | Positioning and Fixing .....                  | 17 |

|  |    |
|--|----|
| 5.6 Air Duct Design and Installation.....            | 19 |
| 6Electrical Installation Instructions .....          | 20 |
| 6.1 Cable Requirements.....                          | 20 |
| 6.2 Wiring Specifications.....                       | 20 |
| 6.3 Fixing and Protection of Connecting Cables ..... | 21 |
| 6.4 DC Side Wiring.....                              | 23 |
| 6.5 AC Side Wiring.....                              | 24 |
| 6.6 Communication interface .....                    | 25 |
| 6.7 System Grounding.....                            | 26 |
| 6.8 Installation Complete.....                       | 26 |
| 7 Commissioning .....                                | 27 |
| 7.1 Check before Starting.....                       | 27 |
| 7.2 Power on/off operation process.....              | 28 |
| 7.3 Fault shutdown operation process .....           | 28 |
| 8 Maintenance and Troubleshooting .....              | 28 |
| 8.1 Description .....                                | 30 |
| 8.2 Precautions .....                                | 30 |
| 8.3 Troubleshooting.....                             | 32 |
| Appendix 1: Technical Parameters .....               | 36 |
| Appendix 2: Quality Assurance.....                   | 38 |

# 1

## About This Manual

### 1.1 Introduction

Dear user, thank you very much for using the power conversion system developed and produced by Shenzhen Kstar New Energy Co., Ltd. We sincerely hope that this product can meet your needs. We also look forward to your valuable opinions on the performance and functions of this product. We will continue to improve.

### 1.2 Applicable Products

This manual is suitable for the industrial and commercial power conversion system of Shenzhen Kstar New Energy Co., Ltd.: KAC50DP

※ Unless otherwise specified, all references to “PCS” and “power conversion system” in this manual refer to this series of products.

### 1.3 Naming Rules of Product Models

| Field 1 | Field 2 | Field 3   | Field 4 | Field 5 | Field 6 | System model |
|---------|---------|-----------|---------|---------|---------|--------------|
| K       | A       | C         | 50      | D       | P       | KAC50DP      |
| KSTAR   | AC      | Converter | Power   | Outdoor | PV      |              |

### 1.4 Manual Description

- This Manual is a special instruction manual for the KAC50DP series provided by Shenzhen Kstar New Energy Co., Ltd. The Manual introduces product-related information, installation instructions, operation, maintenance, and troubleshooting in detail. Before installing and commissioning the equipment, please read and understand all the instructions contained in this Manual, and be familiar with the relevant safety symbols.
- Readers need to have certain knowledge in electrical theory, electrical wiring and equipment. Please read this Manual carefully before installing this product, and ensure that the relevant personnel can easily obtain and use it.
- The content, pictures, logos and symbols used in this Manual are owned by Shenzhen Kstar New Energy Co., Ltd. It is prohibited to publicly reproduce all or part of the content without written authorization of Kstar.

## 1.5 Description of Signs



In order to ensure the personal and property safety of users when using this product, and make better use of this product, relevant information is provided in the Manual and highlighted with appropriate symbols.

Below list the symbols that may be used in this Manual. Please read it carefully.

|   |  |
|---|--|
|  | <p><b>Danger</b><br/>Indicate a situation that has a high degree of potential hazard, which will result in death or serious injury if not avoided.</p> |
| <b>DANGER!</b>  |  |



|   |   |
|---|---|
|  | <p><b>Warning</b><br/>Indicate that there is a moderate potential hazard, which may cause death or serious injury if not avoided.</p> |
| <b>WARNING!</b>   |   |

|  |  |
|--|--|
|  | <p><b>Caution</b><br/>Indicate that there is a low-level potential hazard, which may cause moderate or light injury to personnel if not avoided.</p> |
| <b>BE CAREFUL!</b>   |  |

|   |  |
|---|--|
|  | <p><b>Attention</b><br/>Indicate that there is a potential risk, which may cause the equipment to fail to operate normally or report a failure if not avoided.</p> |
| <b>NOTE!</b>  |  |
|  |  |

“Description” emphasizes and supplements the content and may also provide techniques for optimizing the use of the product.

Please always pay attention to the hazard warning symbols on the equipment. The symbols include:

| Symbol  | Description  |
|---|--|
|  | This symbol indicates that the equipment contains high voltage inside and touching it may cause electric shock.  |
|  | This symbol indicates that the temperature here is higher than the acceptable range for the human body. Do not touch it in order to avoid personal injury. |
|  | This symbol indicates the protective ground (PE) terminal, which needs to be firmly grounded to ensure the safety of the operator.                         |

# 2

## Safety Instructions

### 2.1 Personnel Requirements

- Only professional electricians or qualified personnel are allowed to perform operations on this product.
- The operators should be fully familiar with the structure and working principle of the whole power conversion system.
- The operators should be fully familiar with this User Manual of KAC50DP Power Conversion System.
- The operators should be fully familiar with the relevant standards of the country/region where the project is located.



**WARNING!**

#### Warning

- It is strictly forbidden to perform maintenance or overhaul operations when the equipment is live!
- When maintaining or overhauling the equipment, at least **two operators** must be on site. The maintenance or overhaul operations can be performed only when the equipment has been safely disconnected and the power conversion system has discharged after 10 minutes.

### 2.2 Safety Warning Operation

During the installation, daily maintenance and overhaul of the power conversion system, abide by the following in order to prevent unrelated personnel from approaching and causing misoperation or accidents:

- Set up conspicuous signs at the front and rear switches of the power conversion system to prevent accidental switching.
- Set up warning signs or safety warning belts near the operation area.
- After maintenance or overhaul, be sure to lock the upper cover.

### 2.3 Protection of Symbols on Equipment Body

- The warning symbols on the power conversion system contain important information for safe operation of the power conversion system. Man-made tearing or damage is strictly prohibited!
- A nameplate is installed inside the front door of the power conversion system. The nameplate contains important parameters of the product. Man-made tearing or damage is strictly prohibited!
- If any symbol is damaged or blurred, please contact Shenzhen Kstar New Energy Co., Ltd.



**NOTE!**

#### Attention

- Please ensure that the symbols on equipment body are clear and readable at all times.
- Once any symbol is damaged or blurred, it must be replaced immediately.

## 2.4 Matters on Electricity Safety

### 2.4.1 Electrical safety

|   |   |
|---|---|
| <br><b>DANGER!</b> | <p><b>Danger</b></p> <p>Please ensure that the equipment is well grounded before use!</p> |
|---|---|

|   |   |
|---|---|
| <br><b>DANGER!</b> | <p><b>Danger</b></p> <p>There is a lethal high voltage inside the product!</p> <ul style="list-style-type: none"><li>● Do not touch the terminals or conductors connected to the grid circuit.</li><li>● Pay attention to all instructions or safety documents about connecting to the power grid, and follow the warning symbols on the product.</li><li>● Observe the safety precautions listed in this Manual and other related documents of this equipment.</li></ul> |
|---|---|

|   |   |
|---|---|
| <br><b>DANGER!</b> | <p><b>Danger</b></p> <p>Damaged equipment or system failure may cause electric shock!</p> <ul style="list-style-type: none"><li>● Before operation, visually inspect the equipment for damage or other hazards.</li><li>● Check whether other external equipment or circuit connections are safe.</li><li>● Confirm that the equipment is in safe state before operation.</li></ul> |
|---|---|

### 2.4.2 Electrostatic safety

|   |   |
|---|---|
| <br><b>NOTE!</b> | <p><b>Attention</b></p> <p>Electrostatic sensitive components on the circuit board or elsewhere may be damaged due to improper operation or contact by the operator.</p> <ul style="list-style-type: none"><li>● Operators are required to avoid unnecessary contact with the circuit board.</li><li>● Operators are required to comply with electrostatic protection regulations, such as wearing ESD wristband.</li></ul> |
|---|---|

## 2.5 Requirements of Environmental Space

### 2.5.1 Escape passage requirements

To ensure that the operator can quickly evacuate the scene in the event of an accident, please observe the following:

- Do not place flammable or explosive materials around the power conversion system.
- It is strictly forbidden to stack debris in the escape passage or occupy the escape passage in any form.

### 2.5.2 Moisture protection

Do not open the cover in high humidity or rainy days!

## 2.6 Specification of Live Test

### 2.6.1 Live measurement

|   |  |
|---|--|
| <br><b>DANGER!</b> | <p><b>Danger</b></p> <p>There is high voltage in the equipment. Accidental contact may cause fatal electric shock. Therefore, during live measurement, be sure to:</p> <ul style="list-style-type: none"> <li>● Take proper protection (such as wearing insulating gloves, insulating shoes, etc.).</li> <li>● At least <b>two operators</b> must be on site to ensure personal safety.</li> </ul> |
|---|--|

### 2.6.2 Use of measuring equipment

In order to ensure that the electrical parameters meet the requirements, it is necessary to use related electrical measurement equipment when performing electrical connection and trial operation of the power conversion system.

|  |  |
|--|--|
| <br><b>WARNING!</b> | <p><b>Warning</b></p> <ul style="list-style-type: none"> <li>● Select high-quality measuring equipment that meets the requirements of the site, such as range and applicable conditions.</li> <li>● Ensure that the connection and use of the measuring equipment are correct and standardized to avoid arcing and other dangers.</li> </ul> |
|--|--|

## 2.7 Parameters Setting

The parameters are closely related to the operation of the power conversion system. The operating conditions of the system and the power conversion system must be reliably analyzed and evaluated before these parameters can be modified. The specific parameters are set in the background (PC or EMS).

|  |   |
|--|---|
| <br><b>WARNING!</b> | <p><b>Warning</b></p> <ul style="list-style-type: none"> <li>● Inappropriate parameter settings may affect the normal function of the power conversion system!</li> <li>● Only authorized professionals can set the parameters of the power conversion system.</li> </ul> |
|--|---|

## 2.8 Maintenance or Overhaul Specifications

Pay attention to the following points when performing maintenance or overhaul operations on the equipment:

- Ensure that the power conversion system will not be re-powered accidentally.
- Use a multimeter to ensure that the internal discharge of the power conversion system has been completed.
- Ensure that the equipment is properly grounded.
- Live parts must be insulated and covered with insulating materials.
- The upper cover can be opened for maintenance or overhaul of the power conversion system after at least 10 minutes when the power conversion system has been shut down and the AC-DC power supply has been disconnected.
- During the entire process of maintenance and overhaul, it is necessary to ensure that the escape passage is completely unblocked.

## 2.9 Product Scrapping

- When the power conversion system needs to be discarded, it mustn't be treated as conventional waste.
- Please contact the local authorized professional recycling agency.

## 2.10 Other Precautions

The actual operation summary should be based on site needs, and the following protective or emergency measures should be taken:

- When performing equipment maintenance, overhaul and other operations, relevant personnel should take appropriate protective measures as needed, such as wearing noise-proof earplugs, insulating shoes and anti-scald gloves.
- The installation location of the power conversion system is usually far away from the urban area. Corresponding emergency rescue facilities should be prepared for implementation when needed.
- Take all necessary auxiliary measures to ensure the safety of personnel and equipment.



**NOTE!**

### Attention

All operations on the power conversion system must comply with the relevant standards of the country/region where it is located.



All descriptions in this Manual are for the power conversion system with standard configuration. If you have special needs, please explain to the staff of Shenzhen Kstar New Energy Co., Ltd. when ordering. Please refer to the actual product you received for details.

This Manual can't cover all possible situations in the process of operation, maintenance, and inspection. If you have any question, please contact Shenzhen Kstar New Energy Co., Ltd. in time.

# 3

## Product Introductions

---

### 3.1 Power Conversion System

On the power generation side, Power Conversion System (PCS) can effectively connect renewable energy power generation such as solar power and wind power to the power grid; on the transmission side, it can respond to the power grid and achieve peak and frequency modulation, and peak load shifting to coordinate with grid dispatch and stabilize the frequency of the power grid; when used on the power distribution side, it can achieve peak load shifting to alleviate the power shortage during the peak period of power consumption and smoothing the waste caused by excess electric energy when the power consumption is low; on the power consumption side, it can be used as a large uninterruptible power supply. It can control the charging and discharging process of the battery, carry out AC/DC conversion, and directly supply power to the AC load without power grid. PCS is composed of DC/AC bidirectional converter, DC/DC bidirectional converter, MPPT converter, control unit, etc. The PCS controller receives the background control command through communication, controls the converter to charge or discharge the battery according to the symbol and size of the power command, so as to realize the adjustment of the active power and reactive power of the grid. PCS controller communicates with BMS through CAN interface to obtain the status information of the battery pack, which can realize protective charging and discharging of battery and ensure the safety of battery operation.

## 3.2 Product Appearance

The appearance of the power conversion system and the introduction of external components are shown in the following figures:

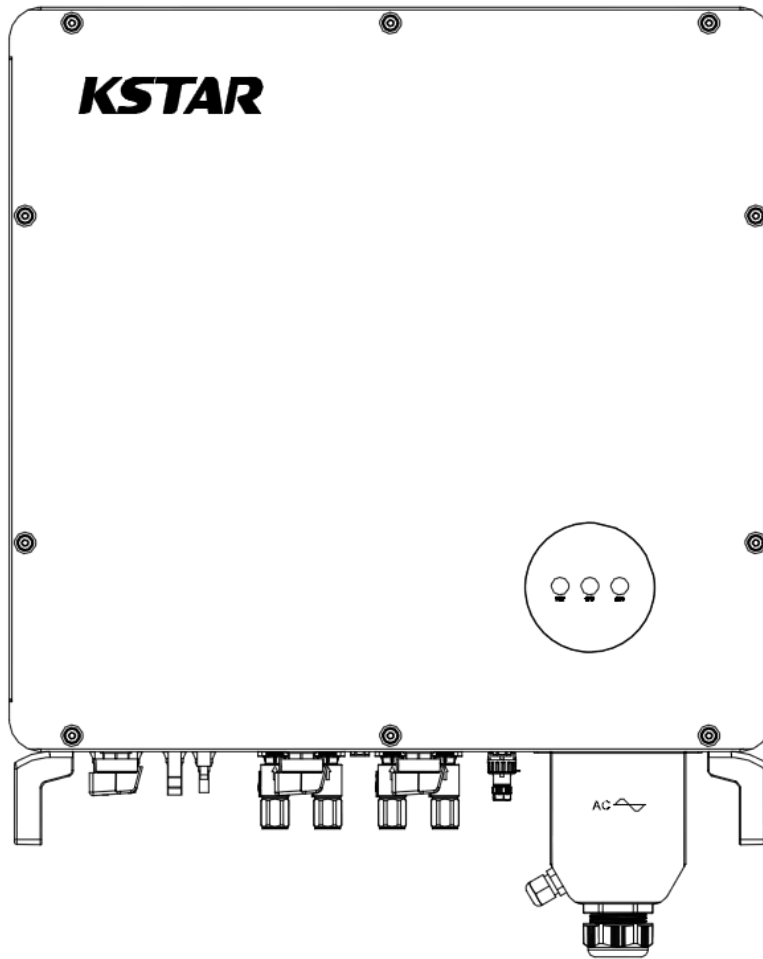

Figure 3-1 Front view of KAC50DP

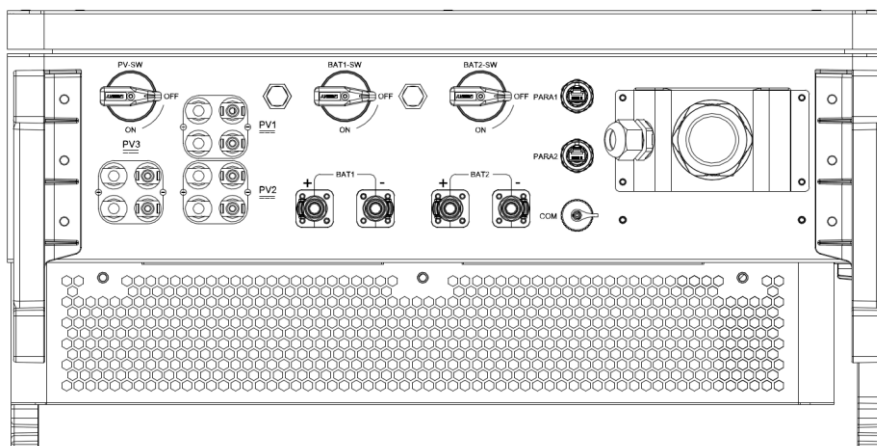

Figure 3-2 Bottom view of KAC50DP

### 3.3 Main Power Topology

The PCS adopts two-phase staggered BOOST-BACK+T-type three-level topology to realize four-quadrant operation; the filter circuit adopts an LCL filter circuit.

The principle of the main circuit inside the power conversion system is shown in the figures below:

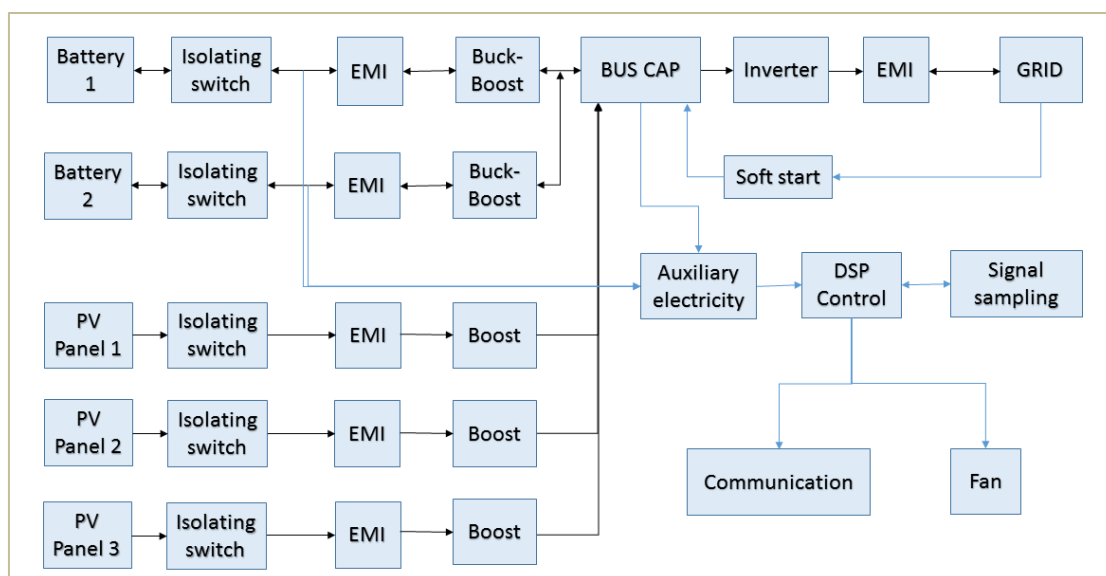

Figure 3-3 KAC50DP main circuit topology

### 3.4 Product Features

KAC50DP power conversion system adopts advanced digital control technology to optimize control performance and improve system reliability. It is suitable for different battery charging and discharging needs and the main performance features are as follows:

- Accept power grid dispatch, communication method includes CAN, RS485, etc.
- Multiple working modes such as on-grid mode, off-grid mode, and hybrid mode.
- Independent and controlled frequency and voltage regulation.
- With off-grid independent inverter function, a micro-grid system is established by the power conversion system to ensure the power supply of important loads.
- Off-grid with strong three-phase unbalanced load capacity.
- High frequency design scheme, high power density.
- Use AC/DC dual auxiliary power supply mode to improve reliability.
- Independent air duct, excellent heat dissipation.

### 3.5 Communication Scheme

#### 3.5.1 Background communication scheme

The PCS communicates with the EMS through RS485, and the EMS communicates with the PC through Ethernet, and it is monitored by self-designed ESS monitoring software.

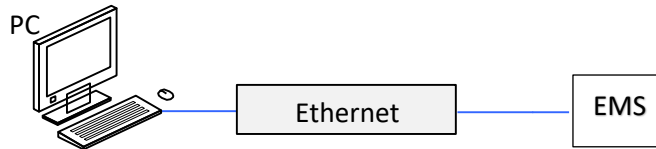

### 3.5.2 EMS communication scheme

Figure 3-4 PC monitoring via Ethernet

Through the RS485 communication line, the PCS can communicate with the EMS, and it can be monitored in real time by self-designed ESS monitoring software.

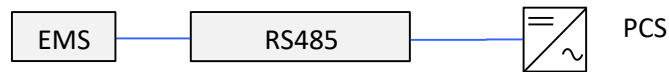

Figure 3-5 EMS monitoring via RS485

### 3.5.3 BMS communication scheme

Through the CAN communication line, the PCS can communicate with the BMS to realize data transmission.

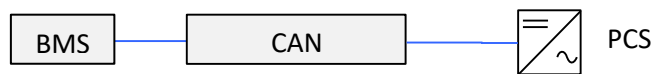

Figure 3-6 BMS transmits data through CAN

## 4

## PCS Modes and Functions

## 4.1 Mode Introduction

## 4.1.1 On-grid mode and off-grid mode

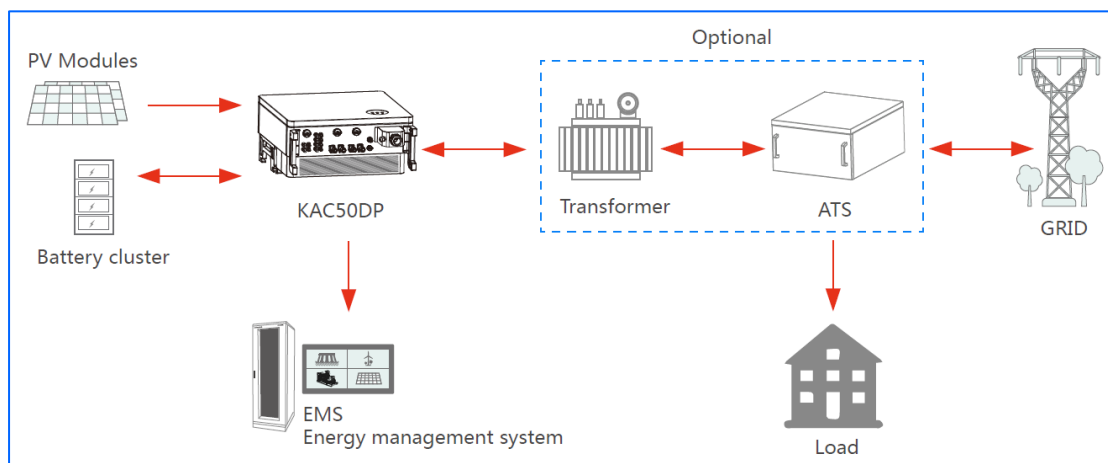

Figure 4-1 System block diagram

On-grid mode: connected to the public grid, following the grid voltage amplitude/phase and frequency, with island protection.

Off-grid mode: in the island state, the PCS operates in voltage source mode and outputs a given voltage and frequency.

On-grid mode, off-grid mode: Mainly according to the on-site power grid situation, manually set the PCS working mode.

## 4.2 PCS Functions

### 4.2.1 Basic functions

- **Self-use:**  
The electricity generated by photovoltaic is stored or directly used by the load.
- **Off-peak power consumption:**  
During the working day, the load is mainly powered by photovoltaic and battery to avoid snatching power at the peak of the power grid; at weekends, the power grid supplies power and stores energy for the load.
- **Peak cutting and valley filling:**  
Through photovoltaic and ESS, the power demand for the grid is reduced during the peak period of power consumption, and increased during the low period.
- **Charge and discharge control of energy storage battery**  
All KAC50DP models can be charged and discharged in on-grid mode. The depth of charging and charging can be set by the user.

### 4.2.3 Cooling system start

The cooling system will automatically start when the PCS reaches a certain power or the temperature reaches a threshold, and the speed will be adjusted steplessly.

## 4.3 Introduction to PCS States

The PCS has 5 states in total, as shown in Table 4-1 below:

Table 4-1 State and Description

| State     | Description  |
|-----------|--|
| Self-test | When the DC side switch is turned on, the DC side of the converter will perform a self-test to detect whether the DC side voltage is normal.   |
| Standby   | After the self-test is completed, the DC side enters the soft-start state, and when the soft-start ends, the DC contactor closes, and the converter is in standby mode.  |
| On-grid   | After the system is in standby mode, if the power grid side is normal at this time, the user can use EMS or PC to set the converter operation mode to on-grid mode. When the converter receives the boot command of the EMS or PC, the relay on the AC side is closed, and the system is in the on-grid operation state. |
| Off-grid  | After the system is in standby mode, the user can use EMS or PC to set the converter operation mode to off-grid mode. When the converter receives the boot command of the EMS or PC, the relay on the AC side is closed, and the system is in the off-grid operation state.  |
| Fault     | All relays of the PCS are disconnected and the system stops working.   |



**WARNING !**

**Warning**

When the PCS fails, it is forbidden to turn it on again. Please turn off the power and check and ensure that there is no problem before powering on again, or else it will cause damage to the machine.

# 5

## Guide for Mechanical Installation

### 5.1 Precautions before Installation

- The installation of this series of PCS requires at least two qualified personnel to operate at the same time, and all electrical installation must comply with local electrical installation standards. Pay attention to prevent falling and smashing.
- When installing, do not touch any other parts inside the chassis except for the wiring terminals.
- Safety signs “Work in progress! Do not switch on!” must be set up at all upstream switches.

### 5.2 Installation Process

The installation process of KAC50DP power conversion system is as follows:

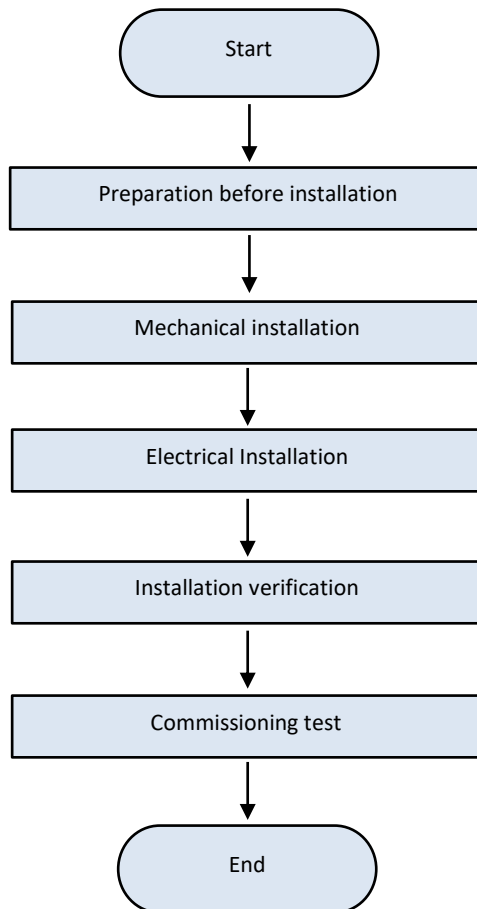

Figure 5-1 Installation flowchart

## 5.3 Preparation for Installation

### 5.3.1 Packaging inspection

Check whether the equipment is damaged before installation. If any transportation damage is found, please contact the transportation company or Shenzhen Kstar New Energy Co., Ltd. and provide a photo of the damage.

### 5.3.2 Checking delivery list

According to the packing list in the box, check whether all the delivered accessories are complete and intact:

Table 5-1 Delivery List

| Item  | Quantity |
|---|----------|
| Converter   | 1 PCS    |
| User manual   | 1 PCS    |
| External PV connection terminal (positive)                            | 6 PCS    |
| External PV connection terminal (negative)                            | 6 PCS    |
| AC OT terminal  | 5 PCS    |
| Certificate   | 1 PCS    |
| Warranty card   | 1 PCS    |
| Mounting bracket (2 mounting bracket assemblies and 1 connecting rod) | 1 PCS    |
| RJ45 line end parallel plug   | 1 PCS    |
| RS485/CAN plug  | 1 PCS    |
| Bolt (M10)  | 4 PCS    |
| Combination screw (M6)  | 2 PCS    |
| Combination screw (M4)  | 2 PCS    |
| Wrench (for removing PV connector)                                    | 1 PCS    |
| L-type wrench (for cover removal)                                     | 1 PCS    |
| External battery connection terminal (positive)                       | 2 PCS    |
| External battery connection terminal (negative)                       | 2 PCS    |

### 5.3.3 Installation tools and parts

The tools and parts needed to install the power conversion system are as follows:

Table 5-2 List of Tools

| Tool                  | Remark  |
|-----------------------|---------|
| Wire stripper         | 1 pcs   |
| Crimping pliers       | 1 pcs   |
| Screwdriver           | 1 set   |
| Sleeve                | 1 set   |
| Multimeter            | 1 set   |
| Inner hexagon spanner | 1 pcs   |
| PV wrench             | 1 pcs   |
| Screws, nuts, washers | Several |

## 5.3.4 Requirements of installation environment

Please confirm the following environment requirements before installing the power conversion system:

Table 5-3 Environmental Requirements

| Item        | Requirement             |
|-------------|-------------------------|
| Temperature | -20°C~50°C              |
| Humidity    | < 95% (no condensation) |

## 5.4 Machine Transportation

### 5.4.1 Transport Instructions



- Transport the power conversion system with packaging as much as possible in order to keep it in a better protective state.
- When using a forklift or crane for transportation, pay attention to the weight of the power conversion system, ensure that the transportation equipment has sufficient load-bearing capacity and arrange supporting or lifting points reasonably.
- Detailed product parameters and transportation requirements are marked on the outer packaging. Please transport according to the signs on the packaging. The illustrations of the PCS packaging signs are shown in Table 5-4 and 5-5:

Table 5-4 Description of Parameters on Package

| Name  | Description                                |
|-------|--|
| MODEL | Model of power conversion system           |
| SIZE  | Package size                               |
| NW    | Net weight of PCS                          |
| GW    | Gross weight of PCS with outer packing box |

Table 5-5 Description of Symbols on the Package

| Symbol  | Description   |
|---|---|
|  | Keep the front side up. Do not place the PCS horizontally, inclined or upside down. |

|   |   |
|---|---|
|  | <p>Handle with care to avoid damage to the power conversion system due to excessive collision and friction in the transportation environment.</p> |
|  | <p>Protect against moisture and avoid rain or moisture on the PCS.</p>  |

## 5.5 Positioning and Fixing

### 5.5.1 Space requirements

- Install indoors/outdoors with good indoor ventilation, no excessive humidity or high temperature source, no corrosive gas.
- Ensure that the ground wire in the power distribution room is properly grounded, and the ground resistance in a dry environment should be less than 4Ω.
- The PCS shall be hanger installed on the side of the battery cabinet or on the wall, and it shall have sufficient bearing capacity.
- Avoid placing it together with flammable and explosive materials and ensure that it meets the fire protection requirements.
- The reserved space size is shown in the figure below:

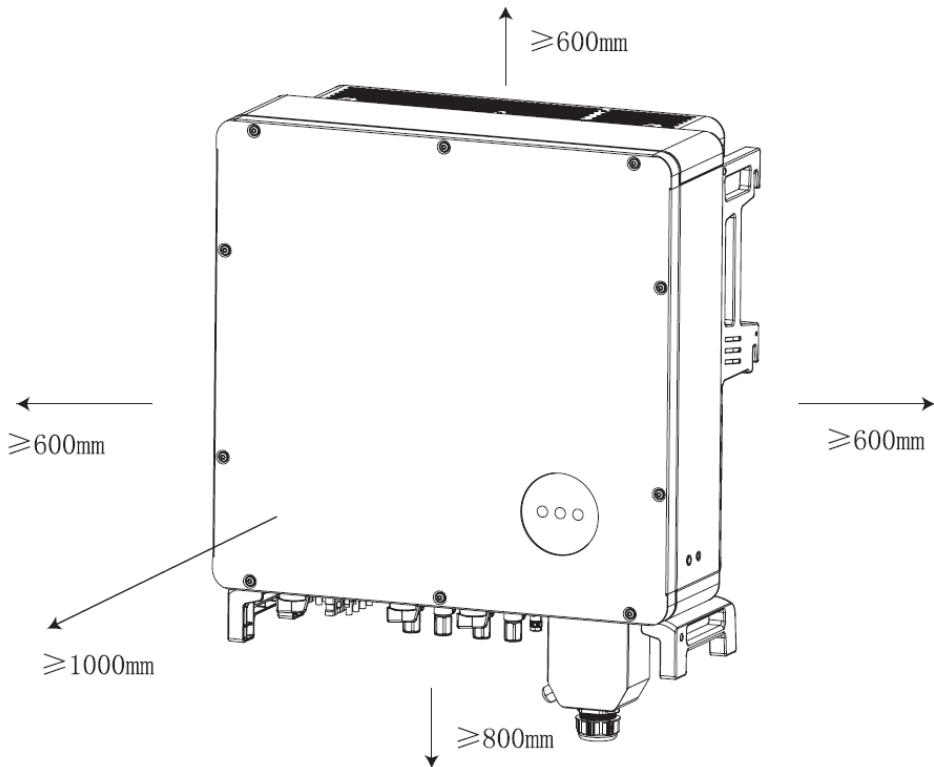

Figure 5-2 Requirements installation space

## 5.5.2 Model dimensions

The mechanical dimensions of the KAC50DP power conversion system are shown in the figure below. Users can design and install according to this data.

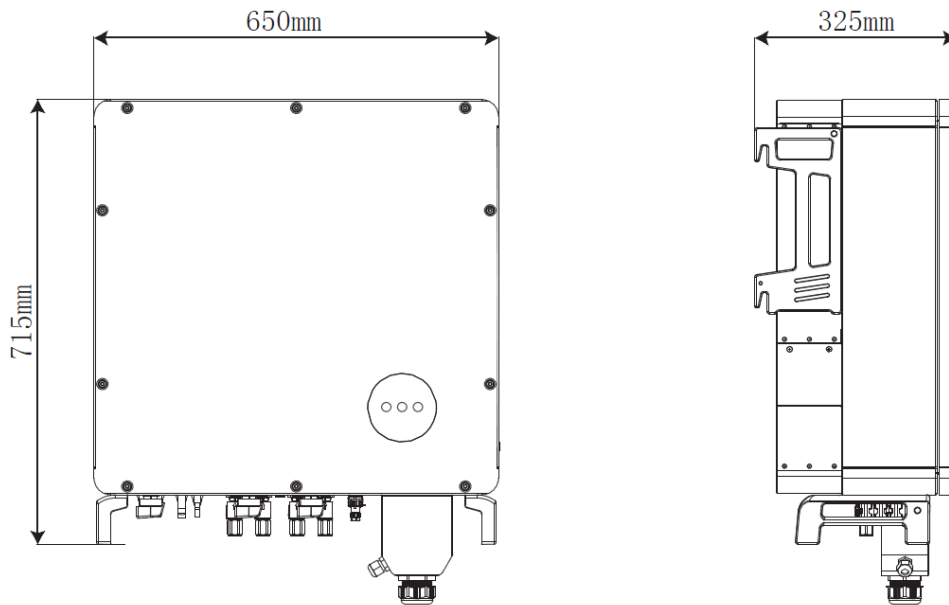

Figure 5-3 Dimensions of KAC50DP model

## 5.5.3 Hanger installation

The bottom of the KAC50DP power conversion system must be reliably connected to the bottom of the foundation. There are fixing holes at the bottom of the power conversion system, which are used to fix the system on the bottom supporting channel steel or on the ground. As shown below:

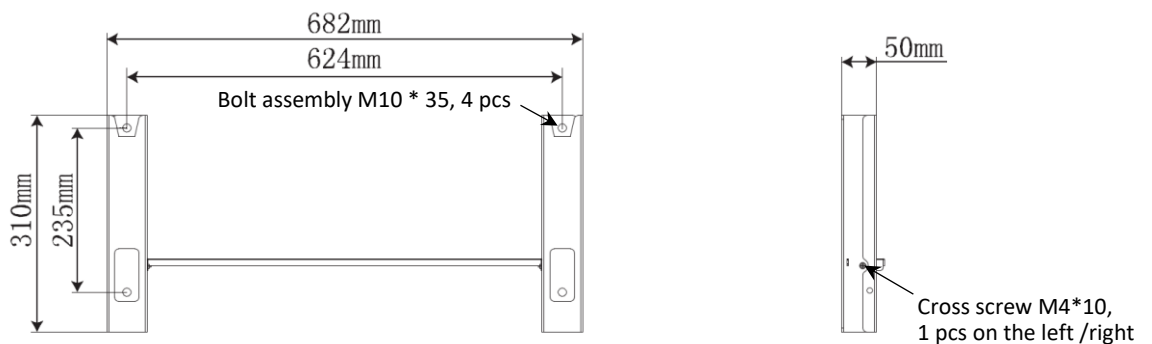

Figure 5-4 Hanger installation and fixation

## 5.6 Air Duct Design and Installation

### 5.6.1 Forced air cooling system

KAC50DP power conversion system use forced air cooling for heat dissipation.

### 5.6.2 Ventilation environment

In order to meet the ventilation requirements of the KAC50DP power conversion system, the installation environment must meet the following requirements:

- The PCS shall not be installed in places with poor ventilation conditions and low air flow.
- The air inlet shall have enough space, and the air outlet shall have enough space to discharge hot air flow.

The schematic diagram of air inlet and air outlet is shown in the figure below.

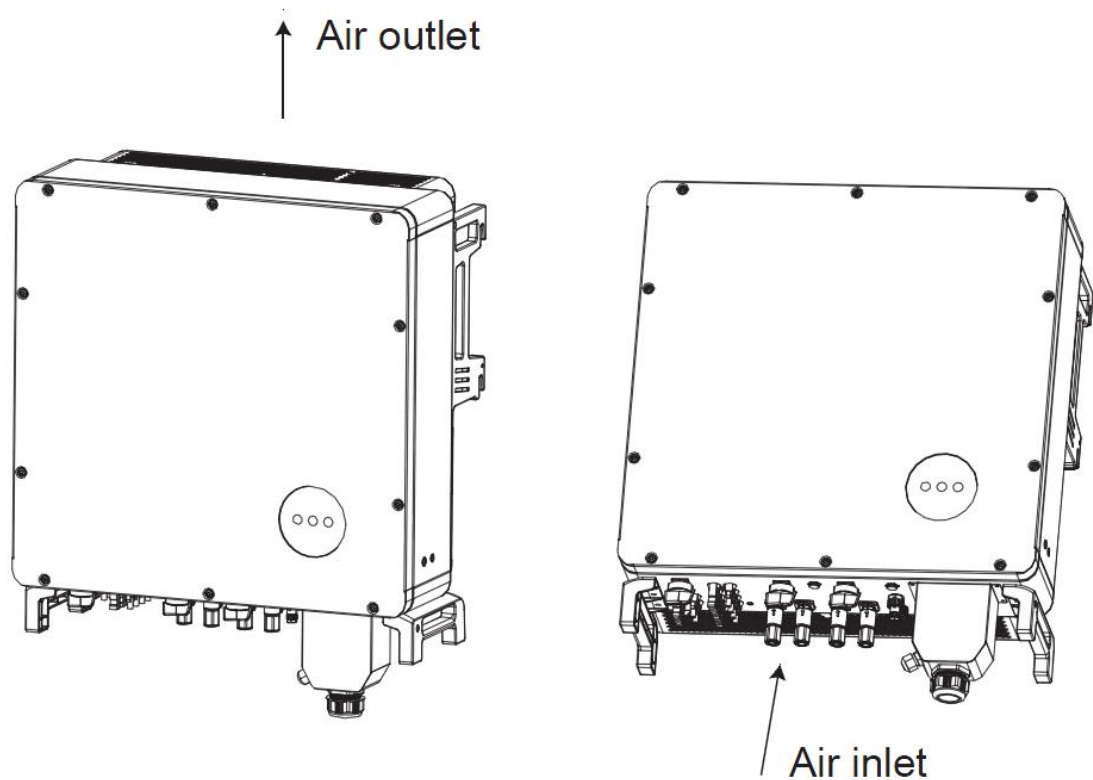

Figure 5-5 Schematic diagram of air inlet and air outlet

## 6 Electrical Installation Instructions

### 6.1 Cable Requirements

According to the capacity configuration requirements of a single KAC50DP power conversion system, it is recommended that the current passing through  $1\text{mm}^2$  wire should not be greater than 6A, and the connecting wires on the same side should be of the same specification and type. Kstar has given the reference requirements of various interface cables. Users can refer to the design related cables according to the table below. When designing cables, follow the instructions in this section and local wiring regulations, and consider the environmental conditions.

Table 6-1 Power Cable Specifications of KAC Power Conversion System

| Model capacity | AC output (each phase)        | Neutral wire         | Ground wire          | Positive/negative DC input (each pole)                             |
|----------------|-------------------------------|----------------------|----------------------|--|
| 50KW           | $\geq 25\text{mm}^2 \times 3$ | $\geq 25\text{mm}^2$ | $\geq 16\text{mm}^2$ | Battery input $\geq 16\text{mm}^2$<br>PV input $\geq 6\text{mm}^2$ |

 The cable size provided in this table is for reference only. The actual selection should be based on the cable working environment temperature, laying method, heat dissipation conditions, etc.



**WARNING!**

**Warning**

Before wiring operation, confirm that the mains power, PV switches and battery switches are disconnected, and affix warning signs to prevent others from operating the switches.



**WARNING!**

**Warning**

Power cables need to be laid in trenches or trunking to avoid mechanical damage to cables or RF interference to peripheral equipment.

### 6.2 Wiring Specifications

When laying cables, communication wires and power wires must be laid separately. The DC loop and AC loop need to be laid separately, and the distance between different cables must be greater than 30mm. When the control cable must pass through the power cable, ensure that the angle between the two cables is kept at  $90^\circ$  as much as possible.

The recommended minimum space distance between parallel shielded data cables and power cables is shown below.

Table 6-2 Spacing between Signal Cables and Power Cables

| Parallel line length (m) | Min space distance (m) |
|--------------------------|------------------------|
| 200                      | 0.3                    |
| 300                      | 0.5                    |
| 500                      | 1.2                    |

※The data cable should be routed as close as possible to the ground or supporting wires, such as supporting beam, steel channel, metal rail, etc.

## 6.3 Fixing and Protection of Connecting Cables

### 6.3.1 Fixing of cables

In order to prevent the copper nose of the wiring from being loosened by force, causing poor contact, or increasing the contact resistance and causing heat or even fire, ensure that the screws that fasten the wiring terminals meet the torque requirements as follows:

The screw torque values are as follows:

M AC output terminal:

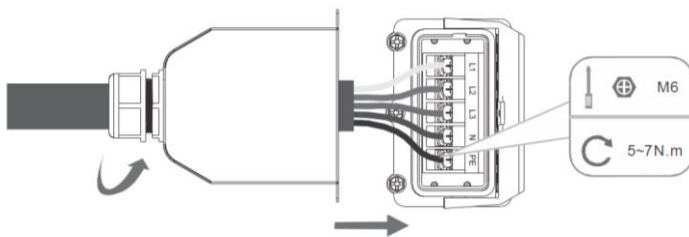

Lock hanger:

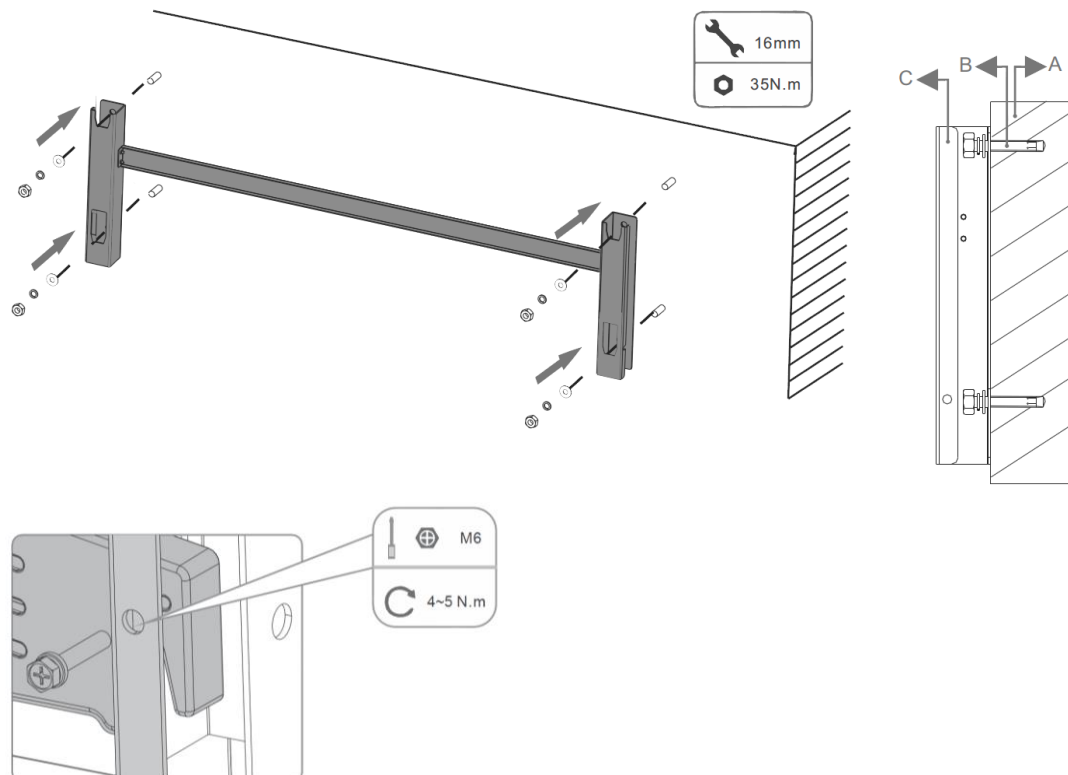

Grounding:

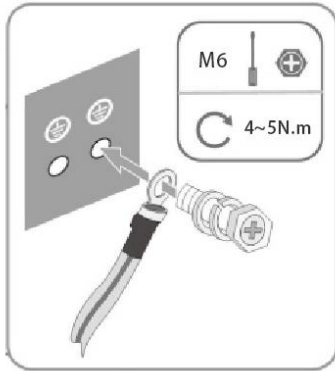

### 6.3.2 Cable protection

Cable protection includes communication cables and power cables. The protection methods are as follows:

Protection of communication cables: The communication cables may be torn off or fall off from the wiring terminal easily during construction as they are thin. It is recommended to connect the power circuit first. Try to run along the cable trough when connecting and fasten with cable ties if there is no cable trough. Avoid heating components and strong electric field loop cables when routing.

Protection of power cables: When installing and connecting, avoid scratches and damage to the cable insulation as this may cause a short circuit. The power cables must also be properly secured.

## 6.4 DC Side Wiring

### 6.4.1 PV side wiring

The DC side wiring correspondence of PV modules connected to KAC50DP power conversion system is shown in Table 6-4 below.

A total of 3 MPPTs, the MPPT voltage access range is 350V~1000V, and the max DC current of each MPPT is 40A. The max PV input power of a single KAC50DP power conversion system is 75KW. Please refer to Section 6.5 for the location of the wiring ports.

Table 6-3

|     |  |
|-----|--|
| PV+ | Connected to the positive terminal of PV array |
| PV- | Connected to the negative terminal of PV array |

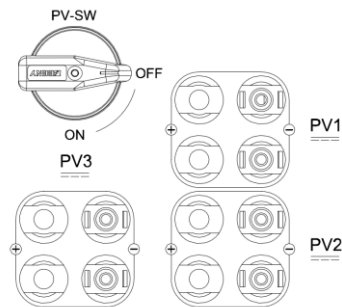

Figure 6-1 PV connection terminal

### 6.4.2 Battery side wiring

The DC side wiring correspondence of the battery connected to the KAC50DP power conversion system is shown in Table 6-5 below.

The battery voltage access range is 350V~750V, and the max DC current is 110A. For a single KAC50DP power conversion system, the power should not exceed 1.1 times the rated power. Please refer to Section 6.5 for the location of the wiring ports.

Table 6-4

|      |  |
|------|--|
| BAT+ | Connected to the positive terminal of battery pack |
| BAT- | Connected to the negative terminal of battery pack |

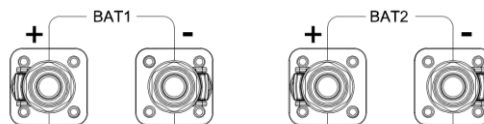

Figure 6-2 Battery connection terminal

## 6.4.3 DC side wiring

The steps are as follows:

**Step 1:** Use a multimeter to confirm whether all terminals of the power conversion system have been powered off.

**Step 2:** Confirm the positive and negative terminals of the cables and make wire labels.

**Step 3:** Connect the positive and negative terminals of the PV array to the "PV+" and "PV-" terminals.

**Step 4:** Connect the positive and negative terminals of the battery pack to the "BAT+" and "BAT-" terminals.



**DANGER!**

**Danger**

In order to avoid personal injury and equipment damage, the power must be cut off before wiring.

- The DC switch is off.
- Use a multimeter to measure that the DC side terminal block is not live.



**WARNING!**

**Warning**

DC voltage limit. Confirm that the PV voltage does not exceed 1000VDC! The battery voltage should not exceed 750VDC!

- Any DC voltage exceeding this limit may cause damage to the power conversion system.
- Equipment damage and loss caused in this case are not covered by the warranty.

## 6.5 AC Side Wiring

### 6.5.1 AC connection

All models of KAC50DP power conversion systems have grid connection. Only the models with bypass need to consider bypass connection. The correspondences are shown in the tables below.

Table 6-5 Correspondence of grid connections

|    |  |
|----|--|
| L1 | Connect to the grid A phase or U phase |
| L2 | Connect to the grid B phase or V phase |
| L3 | Connect to the grid C phase or W phase |
| N  | Connect to the grid N phase            |
| PE | Safe grounding                         |

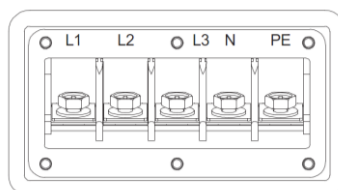

Figure 6-3 AC connection terminal

6.5.2 Steps for AC side wiring:

**Step 1:** Use a multimeter to measure and confirm whether all terminals have been powered off.

**Step 2:** Confirm the phase sequence of the cables and make the wire labels. The AC output 3-phase cables L1, L2, L3, N, and PE should be added with yellow, green, red, black/blue, yellow-green cables respectively to distinguish the phase sequence.

**Step 3:** Correctly connect the ABC (UVW) phases of the grid to the power conversion system according to Table 6-6.

## 6.6 Communication interface

KAC50DP has two external communication interfaces, the functions are shown in the following table:

Table 6-6 Parallel interface PARA connection correspondence

| PIN | Network                       |
|-----|-------------------------------|
| 1   | CAN-H                         |
| 2   | CAN-L                         |
| 3   | Zero-crossing synchronization |
| 4   | GND                           |
| 5   | NC                            |
| 6   | GND                           |
| 7   | Carrier synchronization       |
| 8   | GND                           |

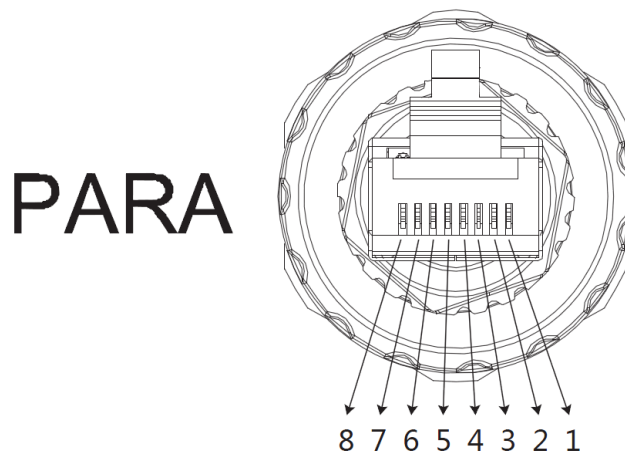
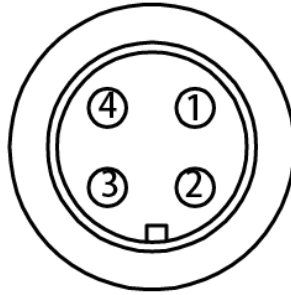

Figure 6-4 Connection diagram of parallel port



| PIN | Network |
|-----|---------|
| 1   | CAN-H   |
| 2   | CAN-L   |
| 3   | RS485-A |
| 4   | RS485-B |

Figure 6-5 Connection Diagram of COM Port

## 6.7 System Grounding

The case of KAC50DP power conversion system needs to be reliably connected with a grounding cable. The resistance must not be higher than  $4\Omega$ , and the diameter of the grounding cable shouldn't be less than  $16\text{mm}^2$ . Refer to section 6.5 Internal Wiring Terminals for the position.

## 6.8 Installation Complete

Only after all mechanical and electrical installations have been completed and confirmed to be correct, can the power-on operation be allowed.

# 7

## Commissioning

### 7.1 Check before Starting

Before commissioning, thoroughly check the installation of the equipment, especially whether the DC and AC terminal voltage meets the requirements of the power conversion system and whether the polarity and phase sequence are correct.

Check whether all connections have met the requirements of relevant standards and whether the system is properly grounded. The grounding resistance is of great significance to the safety of the entire system. It must be confirmed that the grounding resistance meets the requirements before the first commissioning.



**NOTE!**

#### **Attention**

Before commissioning, ensure that all switches on the DC and AC side are off.

#### **Step 1: Check the power conversion system**

- A series of checks are required before turning on the power conversion system:
- Check whether the installation and wiring of the power conversion system are completed according to the contents of Chapter 5 and Chapter 6.
- Ensure that the AC and DC switches are in the open state.

#### **Step 2: Check the voltage on AC side**

- Check whether the three-phase of the power conversion system is correctly connected with the three-phase of the grid.
- Check whether the phase voltage and line voltage are within the predetermined range, and record the voltage value.
- If possible, measure the total harmonic distortion (THD) of voltage. If the harmonic distortion is large, the power conversion system may not operate.

#### **Step 3: Check the voltage on DC side**

- The DC side should be connected to the power conversion system from the battery pack to ensure that the input polarity of each battery pack is correct.



**WARNING!**

#### **Warning**

DC voltage limit. Confirm that the PV voltage does not exceed 1000VDC! The battery voltage should not exceed 750VDC!

## Step 4: Check other content

After completing the above-mentioned inspection, you need to carefully check the following items to ensure that they are correct.

- All connections are made according to the contents of Chapter 6 of this manual.
- The switches on AC side and DC side are disconnected, that is, in “OFF” position.

|   |   |
|---|---|
|  | <p><b>Warning</b><br/>For power conversion systems with a long downtime, the equipment must be thoroughly and meticulously inspected before starting up to ensure that all indexes meet the requirements.</p> |
| <b>WARNING!</b>   |   |

## 7.2 Power on/off operation process

After all the above items are met, the PCS can be started. The operation steps are:

**Step 1:** Close the AC side and DC side switches;

**Step 2:** Check whether the configuration information is normal through the PC or EMS;

**Step 3:** Issue the boot command through the PC or EMS;

**Step 4:** Observe that the green light of the LED is on and the red light is off; otherwise, check the fault code through the PC or EMS.

## 7.3 Fault shutdown operation process

### 7.3.1 Normal shutdown

During normal maintenance or overhaul, shut down the equipment in the following process:

**Step 1:** Send the shutdown command through the PC or EMS;

**Step 2:** Disconnect the AC side and DC side switches;

**Step 3:** Wait until the bus capacitance is discharged and the LED indicator is off.

|   |  |
|---|--|
|  | <p><b>Warning</b><br/>When the machine is working normally, it is strictly forbidden to disconnect the switches directly in order to avoid the risk of arcing and damage to the switches.<br/>In severe cases, the PCS may be damaged.</p> |
| <b>WARNING!</b>   |  |

### 7.3.2 Shutdown at fault or critical moment

When the situation is critical or failure occurs, follow the procedure below:

**Step 1:** Press the system emergency stop button “EPO”;

**Step 2:** Power off the upstream main switch;

**Step 3:** After confirming that the danger or failure is removed and operation is required, reset the EPO button.

|   |   |
|---|---|
|  | <p><b>Warning</b></p> <ul style="list-style-type: none"><li>● The emergency stop button is only used when the machine fails or the situation is critical. When the machine is normally shut down, the shutdown operation should be performed through the key stop command on the PC or EMS.</li><li>● If the situation is critical, you must directly press the emergency stop button to ensure</li></ul> |
| <b>WARNING!</b>   |   |

a quick response.

# 8

## Maintenance and Troubleshooting

### 8.1 Description

Due to the influence of ambient temperature, humidity, dust and vibration, the internal components of the power conversion system will age, which will affect the performance of the system and even cause malfunctions.

Therefore, it is necessary to implement daily and regular maintenance on the power conversion system to ensure its normal operation and service life. All measures and methods that help the power conversion system keep a good working condition belong to maintenance work.

If a malfunction still can't be solved with the help of this manual, please contact Shenzhen Kstar New Energy Co., Ltd. and provide the following information so that we can provide you with better services:

- Photos of the fault site
- Model and serial number of the power conversion system.
- Information about the related components connected to the power conversion system, the configuration of the energy storage battery and grid parameters.
- The communication connection scheme of the power conversion system.
- Fault information and brief description.

### 8.2 Precautions

#### 8.2.1 General safety rules

In order to ensure the safety of operators when performing maintenance or overhaul of the power conversion system, please be sure to observe the following five safety rules:

- Disconnect all external power supply of the power conversion system.
- Ensure that the power conversion system will not be re-powered accidentally.
- Use a multimeter to ensure that the inside of the power conversion system is completely de-energized.
- Ensure that the power conversion system is properly grounded.
- For possible live parts near the operating part, insulating material shall be used for insulation cover.





**WARNING!**

#### **Warning**

Only qualified and authorized personnel can perform maintenance and other operations on the power conversion system.

During maintenance work, do not leave screws, washers and other metal parts in the power conversion system in order to avoid damage to the system!

|  |   |
|--|---|
| <br><b>WARNING!</b> | <p><b>Warning</b><br/>                 If only the switch is disconnected, the cable connection terminals inside the power conversion system are still live!<br/>                 Before opening the machine cover and starting the formal maintenance work, not only the switch, but also the front and rear circuit breakers of the power conversion system must be disconnected.</p> |
|--|---|

|  |  |
|--|--|
| <br><b>WARNING!</b> | <p><b>Warning</b><br/>                 After the power conversion system exits operation, wait at least 10 minutes before operating.</p> |
|--|--|

### 8.2.2 Maintenance work and cycle

Table 8-1 List of Maintenance Items

| Maintenance items  | Maintenance content  | Recommended period |
|--------------------|--|--------------------|
| Keep records       | <ul style="list-style-type: none"> <li>◆ Export and back up data with USB.</li> </ul>  | 1 month            |
| PCS inspection     | <ul style="list-style-type: none"> <li>◆ Observe whether the power conversion system is damaged, deformed or rusted.</li> <li>◆ Listen to whether there is any abnormal sound during the operation of the power conversion system.</li> <li>◆ Observe the parameters during operation through background.</li> <li>◆ Use a thermal imager to check the system heating.</li> <li>◆ Check whether the ventilation, ambient temperature, humidity, dust and other environments around the power conversion system meet the requirements.</li> </ul> | Half a year        |
| Air duct cleaning  | <ul style="list-style-type: none"> <li>◆ Check dust in the air duct, and clean it if it is serious.</li> <li>◆ Listen for abnormal vibration when the fan is running.</li> </ul>   | Half a year        |
| Safety function    | <ul style="list-style-type: none"> <li>◆ Check whether the system EPO button is invalid.</li> <li>◆ Check whether the switch is invalid.</li> </ul>  | Half a year        |
| Circuit connection | <ul style="list-style-type: none"> <li>◆ Check if any electrical connection is loose or has poor contact.</li> <li>◆ Check all cables and the metal surface contact surface for damage or scratches.</li> <li>◆ Check if the insulation tape of any wiring terminal is off</li> <li>◆ Check if the screw position is overheating.</li> </ul>   | 1 year             |
| Symbol inspection  | <ul style="list-style-type: none"> <li>◆ Check the warning signs on the machine body and other equipment symbols,</li> <li>◆ If any symbol is blurred or damaged, replace it in time.</li> </ul>   | 1 year             |

 The table only shows recommended routine maintenance cycles for products. The actual maintenance cycle should be determined in conjunction with the specific installation environment of the product. Factors such as the scale of the power station, its location, and the site environment will affect the maintenance cycle. If the operating environment is sandy or dusty, it is necessary to shorten the maintenance cycle and increase the frequency of maintenance.

## 8.2.3 Replace components

- The replacement of components shall be operated by professionals.
- When replacing the electrical components in the power conversion system, be sure to use the components of the same manufacturer with the same model! The model of the component can be obtained through the label of the power conversion system or the product. If you can't find, please contact Shenzhen Kstar New Energy Co., Ltd.
- If it is necessary to replace products of other manufacturers or different models of the same manufacturer, it must be analyzed and confirmed by Kstar in advance, or else Kstar shall not be liable for any casualties or property losses that may be caused thereby.

## 8.3 Troubleshooting

### 8.3.1 Troubleshooting

|   |  |
|---|--|
|  <p><b>WARNING !</b></p> | <p><b>Warning</b><br/>Under fault conditions, there may still be lethal high voltages inside the power conversion system! Only qualified technicians can perform the operations described in this chapter. "Qualified" means that the operator has participated in the professional training on equipment troubleshooting operations in the early stage. Please only perform the troubleshooting operations described in this manual. When operating, please comply with all safety operating regulations.</p> |
|---|--|

When the power conversion system can't output as expected or the charge and discharge capacity changes abnormally, please pay attention to the following items:

- The open circuit voltage of the energy storage battery
- Whether the machine is in a fault state
- Whether the power grid is correctly connected and powered on
- Check whether the communication of the equipment is normal

### 8.3.2 Non-alarm fault

#### **The machine has big noise**

Check whether the power is within the normal range; measure whether the grid-connected current and voltage waveform are normal; check and replace the cooling fan.

#### **Serial communication mode:**

Check whether all the wiring is in good condition, and whether A/B phases are connected reversely.

The communication adapter does not match; replace the adapter and try again.

Check whether the local address and baud rate are consistent with the PC.

### 8.3.3 Alarm fault

The LED indicator color will display the alarm and fault items (green light: operation; yellow light: alarm; red light: fault), and the corresponding solutions are shown in Table 8-2:

Table 8-2 Alarm Fault Treatment Methods

| Fault type                        | Treatment method   |
|-----------------------------------|--|
| Low battery voltage               | Disconnect the DC switch and check the DC side voltage and the configuration of the energy storage battery |
| High battery voltage              | Disconnect the DC switch and check the DC side voltage and the configuration of the energy storage battery |
| Battery reverse connection fault  | Disconnect the DC switch and check the positive and negative wiring of the energy storage battery          |
| Battery hardware overcurrent      | Turn off, check whether the input and output of the converter are overloaded or short-circuited            |
| PV reverse connection fault       | Disconnect the switch on the PV side and check the positive and negative wiring on the PV side             |
| PV voltage high fault             | Disconnect the PV side switch and check the PV side voltage configuration                                  |
| PV hardware overcurrent           | Turn off, check whether the input at the photovoltaic side is overloaded or short-circuited                |
| High grid overvoltage             | Turn off and check the voltage at the connection point   |
| Low grid voltage                  | Turn off and check the voltage at the connection point   |
| Grid voltage reverse sequence     | Disconnect the power supply switch of the grid, turn off and check the three-phase wiring                  |
| Abnormal grid frequency           | Turn off and check the grid voltage  |
| Output relay fault                | Turn off, check whether the AC relay is damaged  |
| PCS overcurrent                   | Turn off, check whether the input and output of the PCS are short-circuited or the PCS is overloaded       |
| PCS wave-by-wave current limiting | Turn off, check whether the input and output of the PCS are short-circuited or the PCS is overloaded       |
| PCS over temperature              | Turn off, check whether the PCS fan is faulty and whether the air duct is unobstructed                     |
| PCS out of sync                   | Turn off, check the PCS settings, and check whether the parallel cable is connected normally               |
| Lightning protection failure      | Turn off and check the lightning protection of the PCS   |
| BMS communication failure         | Turn off, check whether the communication cable between the PCS and the battery system is loose            |
| EPO fault                         | Turn off, check whether the EPO button is pressed  |

#### 8.3.4 Protection function

The power conversion system has a complete protection function and warning function. When the input voltage or the power grid is abnormal, it can be activated effectively to protect the safe operation of the power conversion system and continue to operate in set mode when the abnormality disappears.

Table 8-3 PCS Alarm and Protection Functions

| Function | Description |
|----------|-------------|
|----------|-------------|

|  |  |
|--|--|
| DC over/under voltage protection             | <p>When the DC voltage of the energy storage battery exceeds the allowable voltage range, the power conversion system will stop working, and display the fault type on the PC or EMS.</p> <p>The power conversion system can quickly detect the abnormal voltage and react.</p>  |
| Grid over/under voltage protection           | <p>When the power conversion system detects that the grid voltage exceeds the allowable voltage range, it will stop working, and display the fault type on the PC or EMS. The power conversion system can quickly detect the abnormal voltage and react.</p>   |
| Grid over/under frequency protection         | <p>When the power conversion system detects that the grid frequency fluctuation exceeds the allowable range, it will stop working, send warning signal at the same time and display the fault type on the PC or EMS. The power conversion system can quickly detect abnormal frequencies and respond.</p>  |
| Island protection                            | <p>When the power conversion system detects that the grid voltage is 0, it will stop working, and display the fault type on the PC or EMS. The power conversion system can quickly detect the abnormal voltage and react.</p>  |
| AC overcurrent protection                    | <p>When the output power of the energy storage battery exceeds the maximum allowable DC input power, the power conversion system will limit the current and work at the maximum allowable AC output power. When it is detected that the AC current is greater than 1.1 times the rated current, the power conversion system will stop working. After returning to normal, the power conversion system should be able to work normally.</p> |
| AC leakage current protection                | <p>The power conversion system has a grounding protection function, and the grounding cable is equipped with a leakage current sensor. When the leakage current exceeds 2A, the machine stops immediately. When the current is lower than 1.5A, the protection can be eliminated. The fault is displayed on the PC or EMS.</p>   |
| IGBT over temperature protection             | <p>The IGBT module of the power conversion system uses a high-precision temperature sensor, which can monitor the temperature of the IGBT module in real time. When the temperature is too high, the DSP will issue an instruction to stop the power conversion system to protect the stable operation of the equipment</p>  |
| Environmental over-temperature protection    | <p>The power conversion system uses a high-precision temperature sensor to monitor the temperature inside the machine in real time. When the temperature is too high, the DSP will issue instructions to stop the power conversion system to protect the stable operation of the equipment.</p>  |
| DC overcurrent protection                    | <p>When the power conversion system detects that the DC current is greater than 1.2 times the rated current, it will stop working, send a warning signal at the same time, and display the fault type on the LCD. After returning to normal, the power conversion system should be able to work normally.</p>  |
| Phase sequence reverse connection protection | <p>When the power conversion system detects that the three-phase voltage phase of the connected power grid is wrong during self-inspection, it will send a warning signal and display the fault type on the LCD. After returning to normal, the power conversion system should be powered on again and pass the self-check before it can work normally.</p>  |
| AC voltage unbalance protection              | <p>When the power conversion system detects that the difference between the three-phase AC voltages exceeds the allowable range, it will stop working, and display the fault type on the PC or EMS. The power conversion system can quickly detect the abnormal voltage and react.</p>   |

|                           |   |
|---------------------------|---|
| Fan failure protection    | The fan of the power conversion system has an automatic detection function. When it is detected that the fan is not running, it can quickly send fault information to the DSP. The DSP will issue an instruction to stop the power conversion system, and it will send a warning signal at the same time and display the fault type on the PC or EMS. |
| AC relay fault protection | When the power conversion system is in standby, on-grid or off-grid state and detect that the AC relay is disconnected, it will stop working, send a warning signal at the same time, and display the fault type on the PC or EMS.  |

## Appendix 1: Technical Parameters

|   |                             |
|---|-----------------------------|
| Model                                   | KAC50DP                     |
| <b>PV input parameters</b>              |                             |
| Max. input voltage                      | 1000V d.c.                  |
| MPPT voltage range                      | 350~800V d.c.               |
| Rated voltage                           | 667V d.c.                   |
| Rated power                             | 75kW                        |
| No. of MPPT                             | 3                           |
| Max. input current per MPPT             | 40A                         |
| Max. short-circuit current per MPPT     | 2                           |
| <b>Battery input parameters</b>         |                             |
| Battery type                            | Lithium-ion                 |
| Battery voltage range                   | 350~750V d.c.               |
| Rated voltage                           | 512V d.c.                   |
| Max. charging current                   | 110A d.c.                   |
| Max. battery input channels             | 2                           |
| <b>Output parameters (AC, on-grid)</b>  |                             |
| Rated AC power                          | 50kW                        |
| Max.AC power                            | 55kVA                       |
| Rated AC current                        | 72A                         |
| Max. AC current                         | 80A                         |
| Rated AC voltage                        | 400V a.c.; 3W/PE            |
| AC voltage range                        | 340~440V a.c                |
| Rated grid frequency                    | 50/60Hz                     |
| AC voltage frequency range              | 45~55Hz/55~65Hz             |
| Total current harmonic distortion (THD) | <3% (Rated power)           |
| Power factor                            | >0.99 (Rated power)         |
| Power factor adjustment range           | 0.9 (leading)~0.9 (lagging) |
| <b>Efficiency</b>                       |                             |
| Max. efficiency                         | 97.50%                      |
| <b>Protection</b>                       |                             |
| DC switch                               | Yes                         |
| DC reverse polarity protection          | Yes                         |
| Insulation impedance detection          | Yes                         |
| Surge protection                        | Yes                         |
| Island protection                       | Yes                         |
| Power grid monitoring                   | Yes                         |
| AC leakage current detection            | Yes                         |
| <b>General parameters</b>               |                             |
| Dimensions (W x H x D)                  | 650*715*325mm               |
| Weight                                  | 75kg                        |
| Isolation mode                          | Non-isolated type           |

|                                     |                                |
|-------------------------------------|--------------------------------|
| Protection grade                    | IP65                           |
| Overvoltage level (DC)              | OVC II                         |
| Overvoltage level (AC)              | OVC III                        |
| Operating temperature range         | -25 °C~+60 °C (45 °C derating) |
| Relative humidity (no condensation) | 0~100%                         |
| Cooling mode                        | Intelligent air cooling        |
| Max. working altitude               | 3000M                          |
| Display                             | LED                            |
| Communication interface             | CAN/RS485                      |

## Appendix 2: Quality Assurance

For products that fail during the warranty period, Shenzhen Kstar New Energy Co., Ltd. will repair or replace with new products free of charge.

### 1. Evidence

During the warranty period, the customer needs to show the invoice and date of purchasing the product. The trademark on the product should also be clearly visible, or else the guarantee will be invalid.

### 2. Conditions

- The nonconforming products after replacement will be handled by Kstar
- The customer should reserve a reasonable time for Kstar to repair the malfunctioning equipment

### 3. Exemption from liability

The following situations are not covered by the warranty:

- The free warranty period of the machine and parts has expired.
- Transport damage.
- Incorrect installation, modification or use.
- Operation in harsh environment beyond description in this manual.
- Machine failure or damage caused by installation, repair, modification or disassembly by service personnel other than our company.
- Installation and use beyond regulations of relevant international standards.
- Machine failure or damage caused by non-standard or non-Kstar components or software.
- For the damages caused by the abnormal natural environment, Kstar can provide charged maintenance services.



Kstar products and product manuals are subject to improvement and upgrading in order to improve customer satisfaction continuously. If there is a difference between the manual and your product, please refer to the specific product. If you still have questions, please contact Kstar.

**KSTAR**

**Shenzhen Kstar New Energy Co., Ltd.**

Address: Kstar Industrial Park, No. 7 Road, West District, High-tech Park, Guangming New District, Shenzhen

Zip code: 518106

After-sales service hotline: 400-700-9662

URL: [www.kstar.com.cn](http://www.kstar.com.cn)

E-mail: [service@kstar.com.cn](mailto:service@kstar.com.cn)

※The product size and parameters are subject to change without prior notice.